



Vibration Switch

VM-90A

Standard Specifications

Pickup Type: VP-A52IW
(Standard Type)

Manufacture: **IMV CORPORATION**

Specification No.: TVE-5-7815E

Total page: 9



Revision

Rev0 1st Apr,2020 New issue.



The product comes with an instruction manual, not a standard specification or delivery specification.

Delivery specifications are available for a fee. Please inquire for details.



INDEX

1. Introduction.....	4
2. Composition.....	4
2-1. General Composition	4
2-2. System Composition	4
3. Specifications.....	5
3-1. General Specifications	5
3-2. Specifications for Vibration Switch	5
3-3. Specification of Vibration Pickup	7
4. VM-90A Connection Diagram	8
5. General.....	9
5-1. Scope of Work.....	9
5-2. Installation Site.....	9
6. Warranty	9



Standard Specifications

1. Introduction

VM-90A series are designed to monitor the vibration all time for the safety check, detection of abnormal operation, fatigue phenomenon and maintenance of rotational machines such as turbines and blowers etc. under running.

The vibration pickup detects the vibration of turbine or blower etc. The detected signal is sent to vibration monitor and processed. Alarm circuit in it compares the signal with the preset alarm level and alarm relay operates when the signal level exceeds the preset level.

Although VM-90A is small instruments, it can select acceleration, velocity, and displacement vibration measurement.

2. Composition

2-1. General Composition

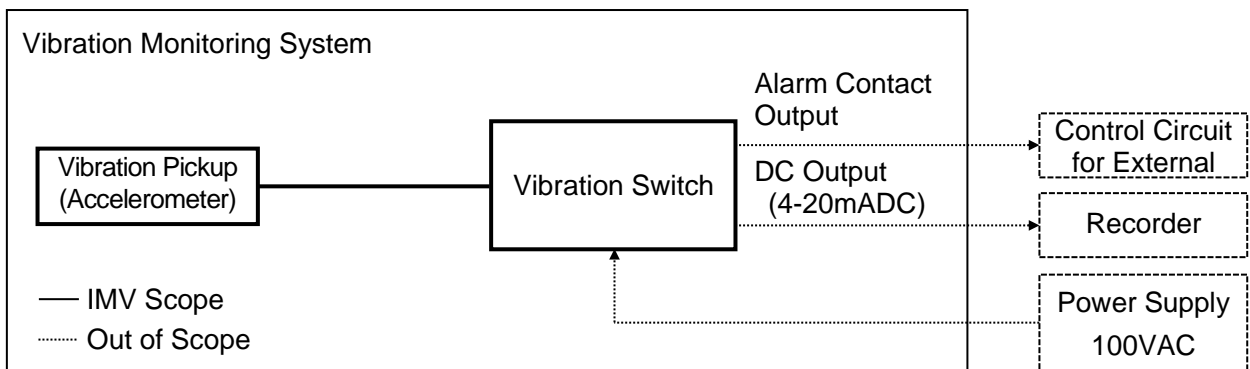

2-2. System Composition

Vibration Switch

Name	Model / Size	Qty	Note
Vibration Switch	VA-90A	1	
Vibration Pickup	VP-A52IW	1	
Pickup Cable (*1)	RG-58A/U/5/TF	5m 1	with TNC Connector and Rubber Cap

Accessories

Name	Model / Size	Qty	Note
Hexagon Wrench Key	3mm	1	
Cross recessed head machine screws with washer	M3×15	4	For Vibration Switch
Small Minus Screwdriver		1	For adjusting or Setting
Instruction Manual		1	with Inspection Sheet

*1 Standard cable length is 5m. Other cable lengths please inquire for details.

*2 The above quantity is for one set.



3. Specifications

3-1. General Specifications

Measuring Frequency Range	Acceleration:	8Hz to 8kHz $\begin{matrix} +1 \\ -3 \end{matrix}$ dB (10Hz to 5kHz ± 1 dB)
	Velocity:	10Hz to 1kHz ± 1.5 dB
	Displacement:	10Hz to 300Hz ± 1.5 dB
Measuring Range	Acceleration:	10m/s ² , 100m/s ²
	Velocity:	10mm/s rms, 100mm/s rms
	Displacement:	100 μ m ^{P-P} , 1000 μ m ^{P-P}

3-2. Specifications for Vibration Switch

Alarm Output	Upper two-stage (ALARM, TRIP)
Alarm Setting Range	Any value setting of 10 to 100% to full scale range
Alarm Contact	Relay 1c Dry contact/1-Alarm
Contact Capacity	30VDC 1A (Resistance Load) 100VAC 0.3A
Delay Time	1 to 10 second
Reset Method	Automatic Reset
Rectification Level Output	4-20mADC (Maximum load resistance 300 Ω)
Monitor Output	3VAC (Peak to Peak) / Full-scale range 2VDC / Full-scale range
Power Supply	100VAC ± 10 V 47 to 63Hz
Power Consumption	Less than 5VA
Operational Environmental	0 to 50°C 35 to 95%RH (No-condensation)
Dimensions	W74×H90×D72mm Mounting Pitch : 60×82, four 3.5-Diameter holes
Weight	Approximately 250g



Outer Dimension of Vibration Switch

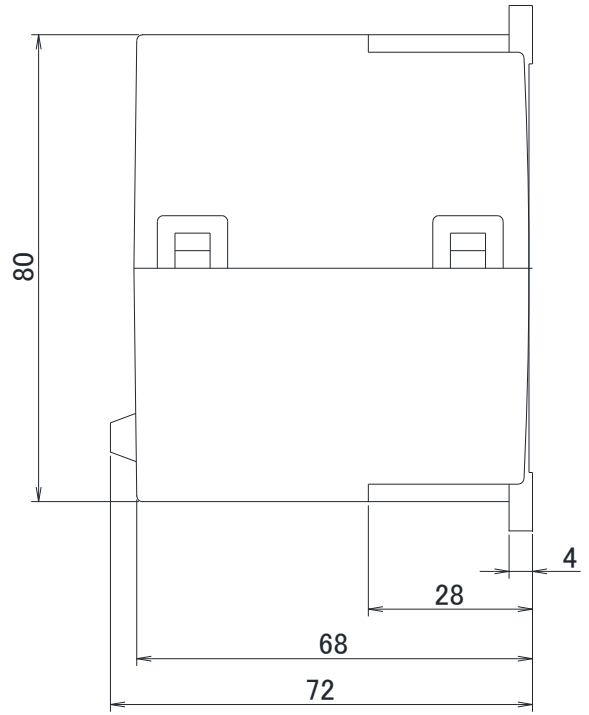
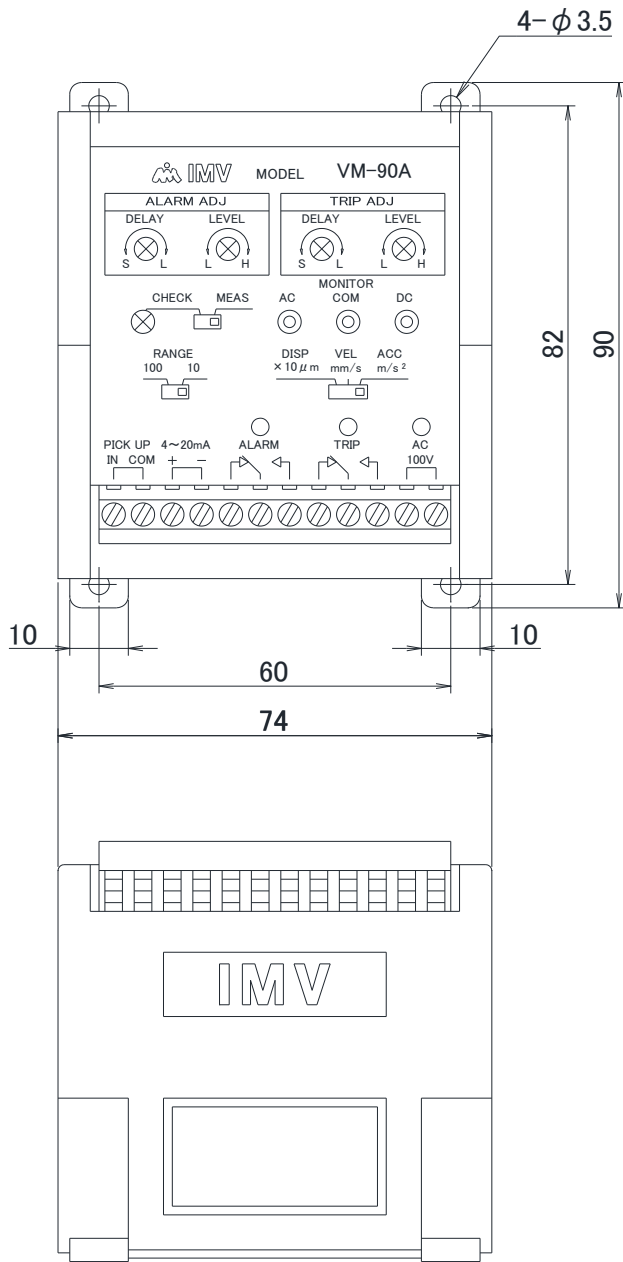

Mounting Dimensions of VM-90A

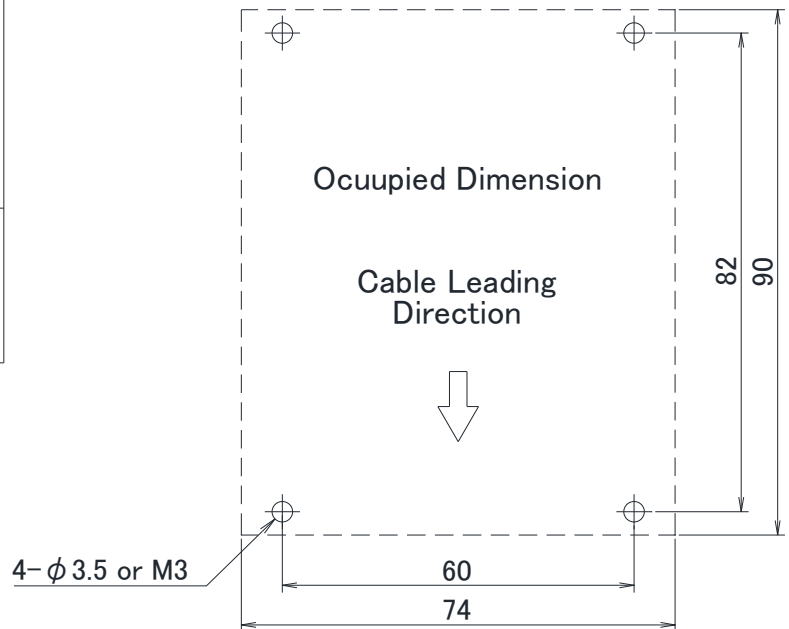



3-3. Specification of Vibration Pickup

Model:	VP-A52IW
Detecting Method:	Compression (Build-in pre-amplifier)
Voltage Sensitivity:	5mV/(m/s ²) ±10% at 160Hz
Resonance Frequency:	Above 35,000Hz
Measuring Frequency Range:	3 to 10,000Hz ±3dB
Maximum Measuring Acceleration:	700m/s ²
Maximum Allowable Acceleration:	5,000m/s ²
Power Supply:	Constant current 0.5 to 10mA, DC 12 to 24V
Output Impedance:	100Ω or less
Ambient Temperature:	-30 to +110 °C (must not freeze)
Structure:	Isolative housing and Waterproof Housing(*)
	(*) Using dedicated pickup cable and sealing the connection point of rubber cap.
Cable Connector:	5.0-diameter coaxial cable RG-58A/U with TNC Connector
Weight:	Approx. 49g (only Pickup)
Housing Material:	Stainless Steel (SUS303)
Dimension:	See below figure

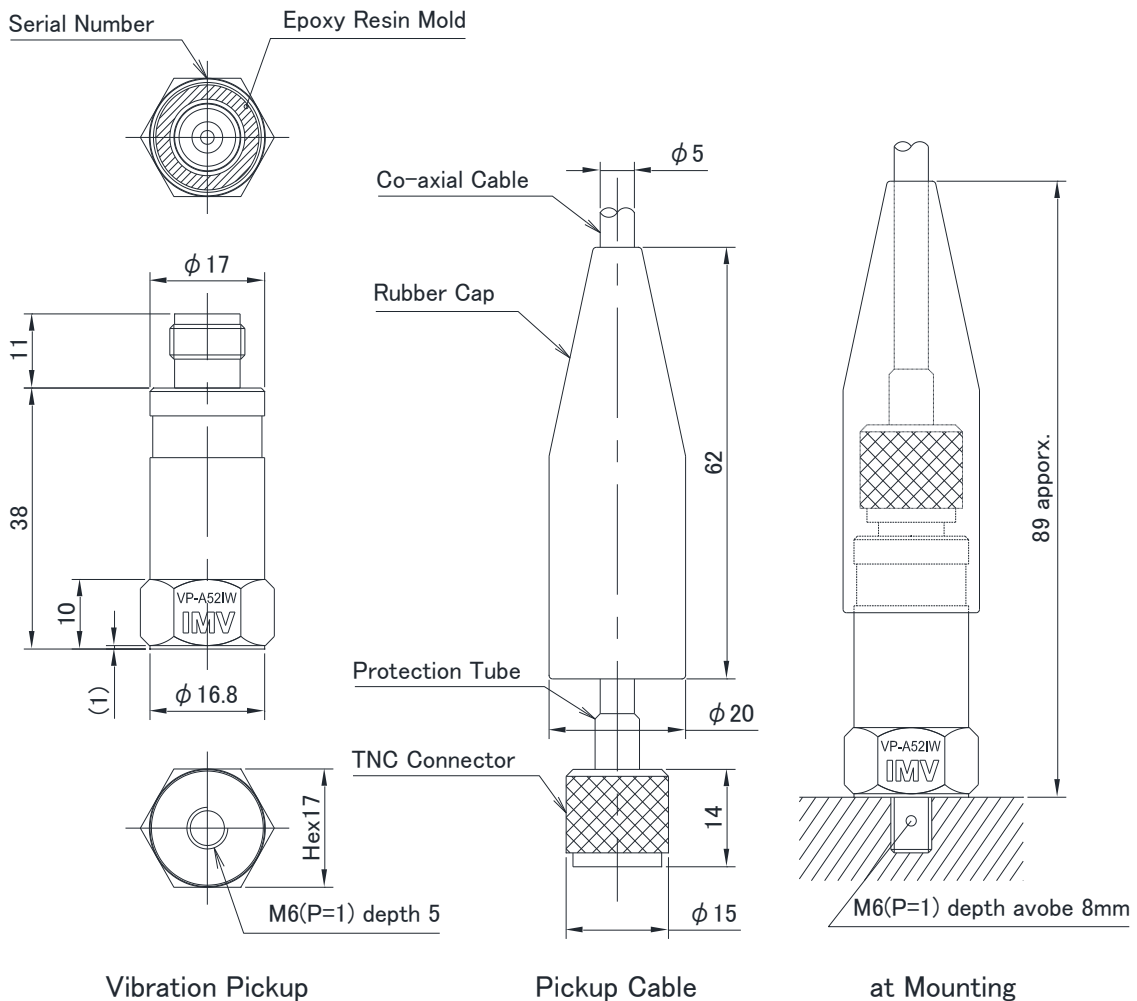



4. VM-90A Connection Diagram

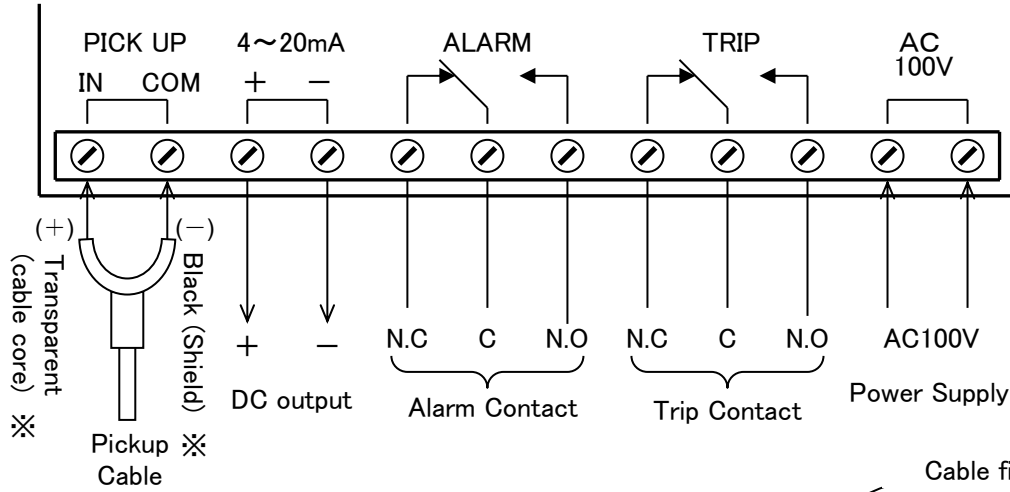

※ The color of the above-mentioned pickup cable is the case of a standard cable. Keep in mind that it may be changed in the case of a special order cable. (It each time and describes.)

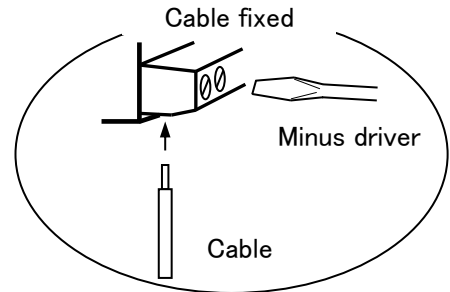

(Note) When relaying a coaxial cable, relay it with a BNC connector. Also, take measures such as storing the BNC connector in a metal junction box so that it is not affected by disturbance noise.

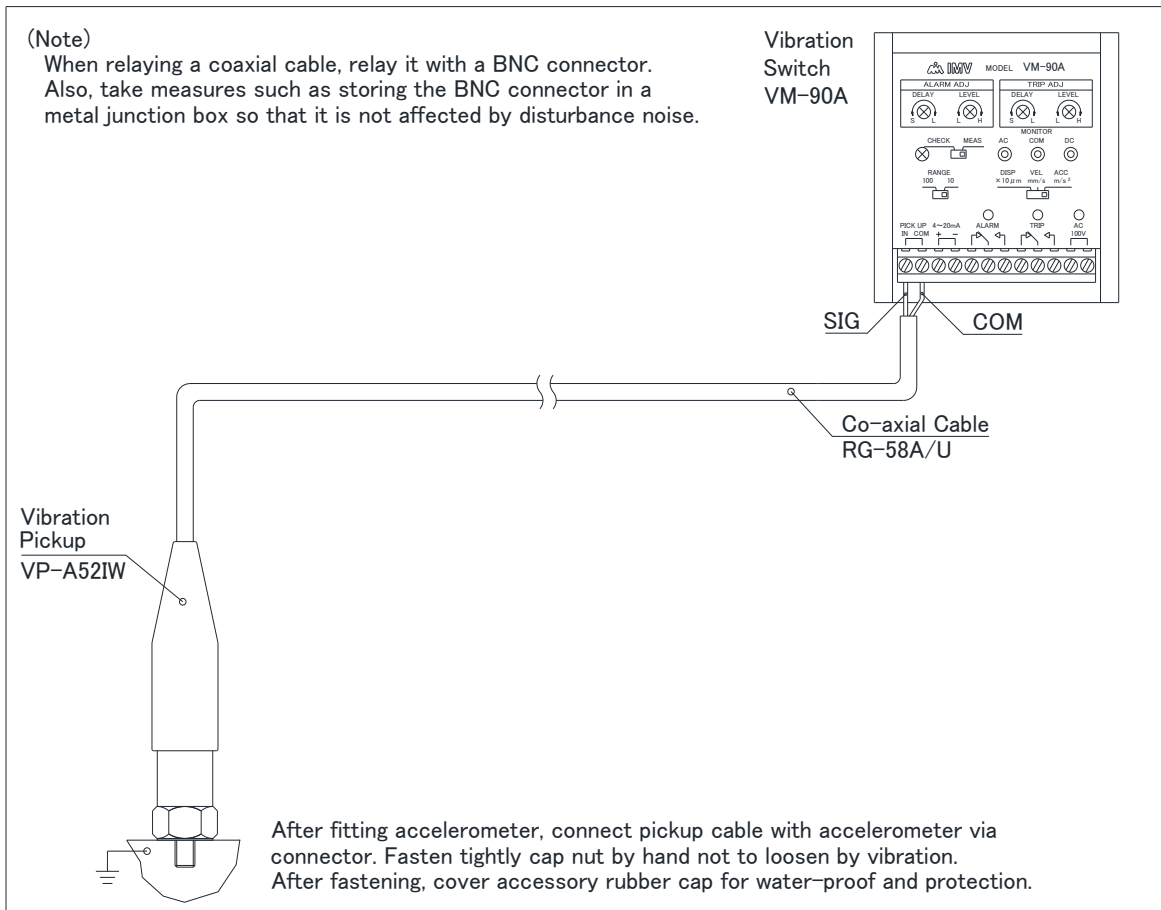



5. General

5-1. Scope of Work

Scope of work for electrical facilities, piping work and panel between customer and IMV is as follows. But special work other than mentioned below, acceptance test and change of specifications will be mentioned on special specifications after the separate arrangement.

Customer work scope:

Commercial power supply, Wiring, Piping, System installation, Connection and related work

IMV work scope:

Production of the unit and Carrying into directed place

5-2. Installation Site

- (1) The ambient condition of installation site is temperature 0 to 50°C, humidity 0 to 85%RH.
- (2) Keep away from dusty place.
- (3) Please specify the installation place.
- (4) Fix it on the concrete which has no hollow under it.

Note: Other specification will be described in Special specifications.

6. Warranty

If there is any breakdown caused by producing error, material fault, or obviously our fault, we repair or exchange with no charge. This condition is valid only in warranty term and the term is for 1 year after delivered. However, even if it is under warranty, it will occur some charge on exchanging.

- (A) Any damage and breakdown caused by natural disaster such as fire, earthquake, flood, lightning damage.
- (B) Any transporting, moving, or dropping which does not related us after finishing our delivery.
- (C) Any error operation, unusual power supply input, and the fault caused by disassembling/repairing/modifying by customer.