

# IMV VIBRATION TEST SYSTEMS

## i series

## Air cooled Vibration Test Systems

# i210 / SA1AM

Vibration tests have diversified and specifications have become increasingly strict. i-series offer a user-friendly lineup with enhanced performance and durability.

### [Expanded maximum test range]

Max. velocity of Sine force: 2.4 m/s • Max. velocity of Shock force 4.6 m/s • Max. displacement: 100 mmp-p

[Patented upper (armature) support system PS Guide] Parallel Slope Guide is standard.

[Low noise] Optimised design of the air intake based on fluid dynamics has reduced the air-intake noise.

[All models can be directly coupled to a climatic chamber.]



### ① High durability with PS guide

PS guide (parallel slope guide) is an upper support system conforming to continued vibration testing at high velocity.



■ PS guide system

### ② Improvement of Testing Environment

With the operation of Intelligence Shaker Management (ISM), EM range can reduce power consumption and CO2 emissions automatically.

eco-shaker

### ③ User first principle

Compatible with K2 vibration controller. Intuitive interface leads The operator with user-friendly guidance.





System Specifications		
System Model	I210/SA1	
Frequency Range (Hz)	0-4000	
Rated Force	Sine (kN)	3
	Random (kN rms) *1	3
	Shock (kN)	9
Maximum Acc.	Sine (m/s <sup>2</sup> )	1000
	Random (m/s <sup>2</sup> rms)	700
	Shock (m/s <sup>2</sup> )	2000
Maximum Vel.	Sine (m/s)	2.2
	Shock (m/s peak)	2.2
Maximum Disp.	Sine (mmp-p)	30
	Maximum Travel (mmp-p)	40

Vibration Generator (i210)	
Armature Mass (kg)	3
Armature Diameter (φ mm)	128
Armature Resonance (Hz)	3200
Allowance Eccentric Moment (N·m)	160
Maximum Payload (kg)	120
Mass (kg)	350

Cooling Blower		
Model	PRVM 350/2R	
Mass (kg)	45	
Environmental Data		
Power Requirement (kVA) *2	6.8	
Input Voltage Supply (3φ, V)	380/400/415/440	
Compressed Air Supply (Mpa)	0.6	
Working Ambient	Temperature (°C)	0 - 40
	Humidity (%RH)	0 - 85

Power Amplifier	
System Model	SA1AM-i10
Maximum Output [kVA]	5
Mass [kg]	240

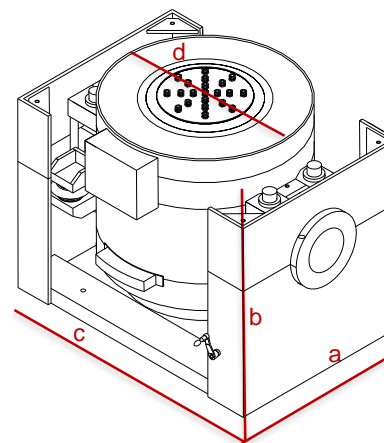

**Shaker**  
Model: i210

a: W 868 mm  
b: H 700 mm  
c: D 458 mm  
d: 458 φmm

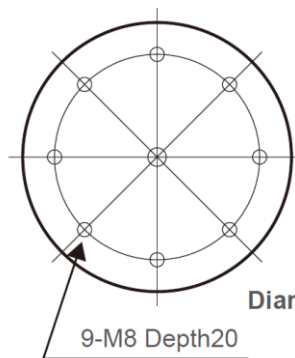

9-M8 Depth20  
(P.C.D.100)

**i210**

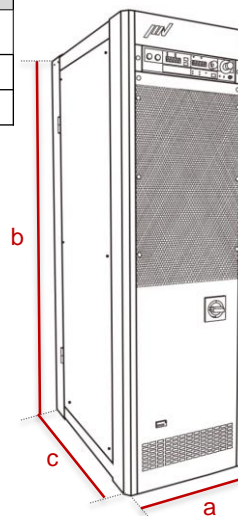

**Amplifier**  
Model: SA1AM-i10

a: W 580 mm  
b: H 1950 mm  
c: D 850 mm

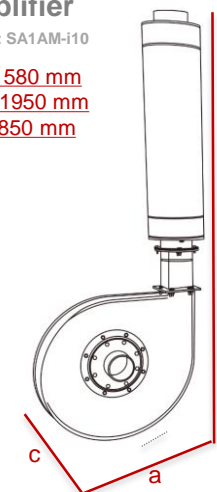

**Blower**

Model: PRVM 350/2R

a: W 600 mm  
b: H 1905 mm  
c: D 557 mm

\*1) Random force ratings are specified in accordance with ISO5344 conditions.  
\*2) Power supply: 3-phase 380/400/415/440 V, 50/60 Hz. A transformer is required for other supply voltages. Please contact IMV or your local distributor with specific test requirements.  
\* The specification shows the maximum system performance. For long-duration tests, de-rating by up to 70 % must be applied. Continuous use at maximum levels may cause failure.  
\* In the case of Random vibration test, please set the test definition of the peak value of acceleration waveform to be operated less than the maximum acceleration of Shock.  
\* Frequency range values vary according to sensor and vibration controller.